

# MAURER Seismic Protection Systems

As unique as the structure they protect

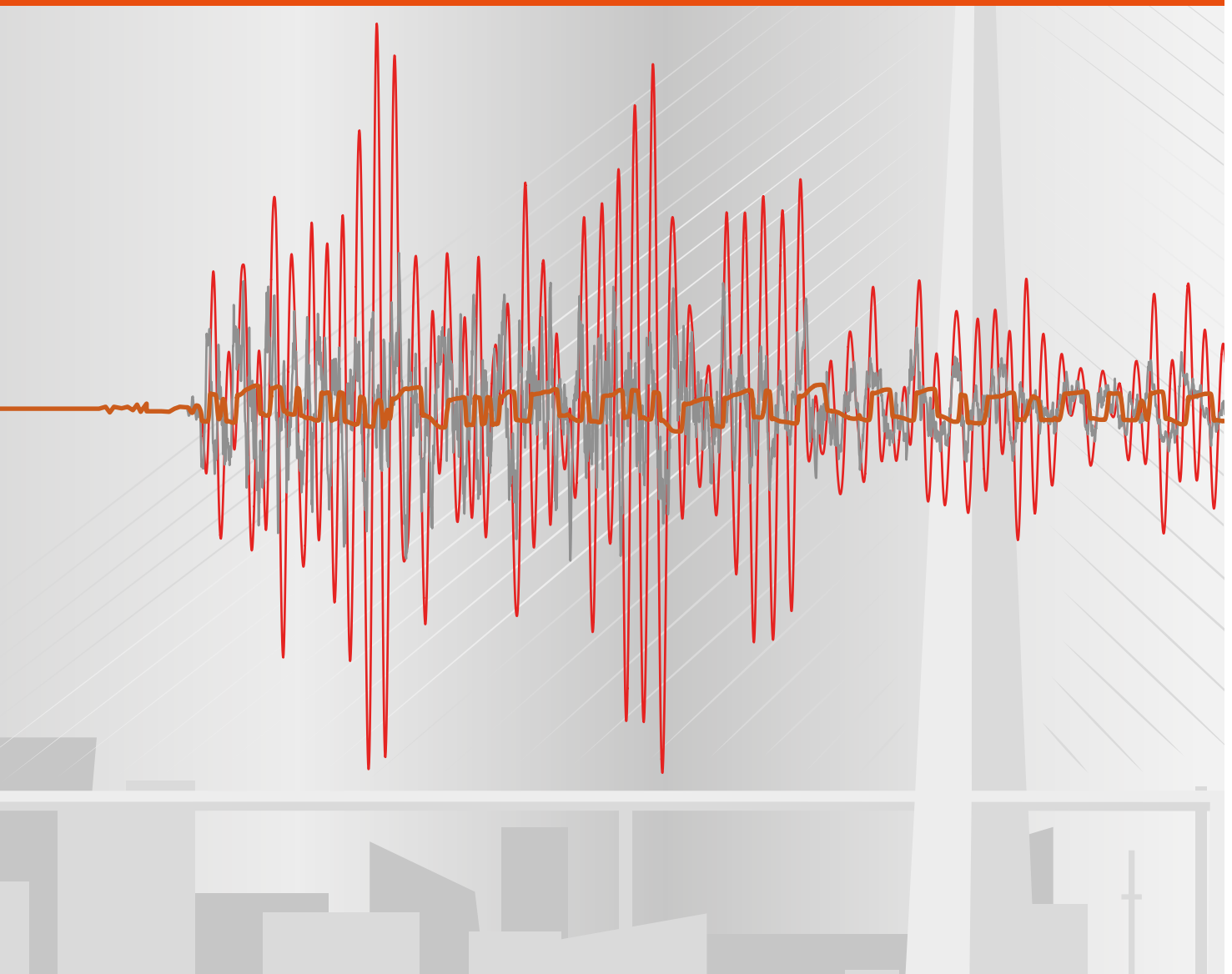

## >> MAURER Seismic Protection Systems Content

Introduction	P. 03
Structural Analysis	P. 05
Basic Concepts of Seismic Protection	P. 06
Strengthening	P. 08
Decoupling and Damping	P. 10
Seismic Expansion Joints	P. 20
Quality, Testing and Monitoring	P. 24
Project-Specific Testing	P. 26
References	P. 27



Baku Tower, Azerbaijan

# MAURER Seismic Protection Systems

## – as unique as the structures they protect

>> “Earthquakes are natural disasters whose feature is that most of the human and economic losses are not due to the earthquake mechanisms, but to failures in man-made facilities, like buildings, bridges etc., which supposedly were designed and constructed for the comfort of the human beings.” (Bertero)

The above observation brings a note of optimism and is encouraging because it tells us that, in the long run, seismic problems are solvable in principle. The task of solving these problems is attributed to Seismic Engineering. The advances in this field have already played a significant role in reducing seismic hazards through the improvement of the built environment, finally making possible the design and construction of earthquake-resistant structures. Progress

has mainly been the result of newly developed design strategies, e.g. Base Isolation, which could not have found useful application without the parallel development of the “seismic hardware” needed for their implementation.

Thus, several research laboratories and industrial concerns have invented and perfected a series of devices that exploit well known physical phenomena which have been adapted to the protection of structures.

MAURER has distinguished itself in this very real race, when in the middle of the 1990s MAURER decided to invest both in human and financial resources, that have led to its present position of worldwide leadership.

>> The purpose of this brochure is:

A) to illustrate the manner in which MAURER has faced and solved the problems deriving from the practical application of the new design strategies.

B) to present the devices that have been developed and perfected towards this goal.

>> MAURER’s philosophy is:

to design its devices on a case-by-case basis, i.e. the “tailor-made” concept, with evident advantages for the customer.

- Best protection
- Lowest total structural cost



Acropolis Museum, Athens  
Sliding Isolation Pendulum (SIP®)

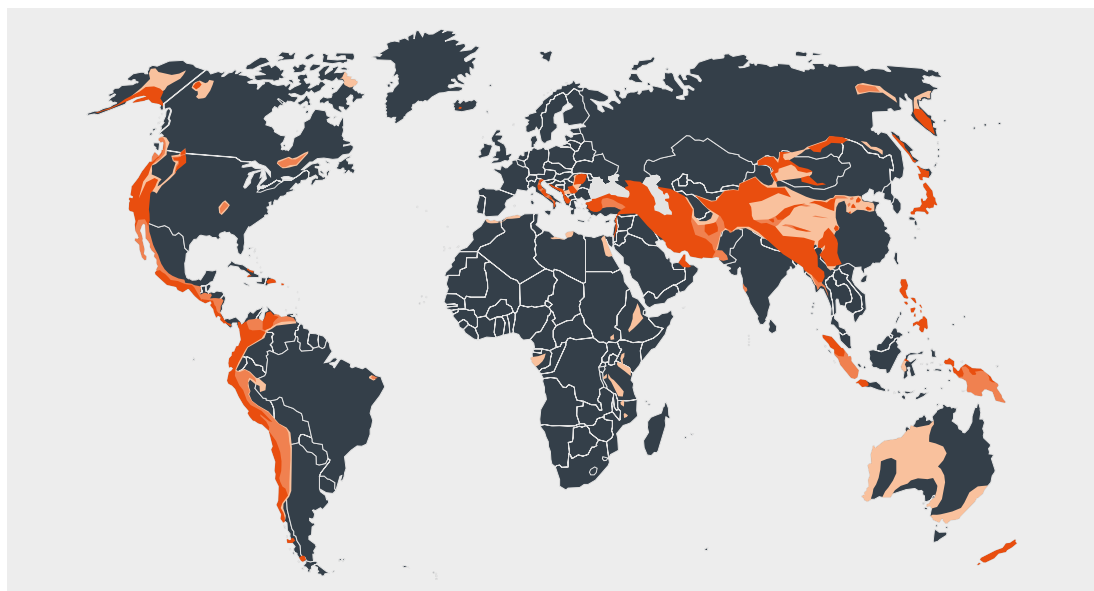

World map of the most significant earthquake zones

## MAURER is more than a supplier of Seismic Hardware



MAURER has acquired vast experience in the application of modern seismic protection technologies within a wide variety of structures to minimise earthquake induced damage.

MAURER's experts offer structural designers and architects assistance in the definition of the protection systems and in the selection of devices best suited for each case, considering not only the seismicity of the site, but also the structural, functional and architectural requirements. By cooperating with wind engineering specialists, FE modeling or testing laboratories, an economical result can be achieved.

ONASSIS House of Letters and Fine Arts,  
Athens - Sliding Isolators SIP® at the  
basement

The efficiency and reliability of the proposed structural protection system is validated by time-based simulation of the structure with an earthquake protection system considering all relevant nonlinearities of the entire system.

### >> Better protection thanks to a wide range of Seismic Hardware solutions

MAURER offers the world's most extensive range of seismic devices so designers may choose the best solution to optimize the seismic protection of your structure. Our specialists can provide technical assistance and budget costs for various earthquake protection alternatives that satisfy code and customer requirements.

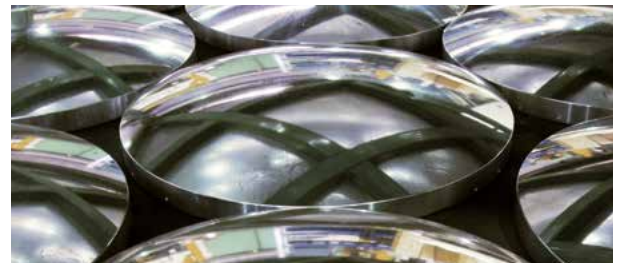

# Seismic Analysis – a tool to optimize the Seismic Protection System

The linear, or modal, analysis method is the most common design approach to predict the structural response in terms of forces and drift due to seismic impact and to design the structural protection system. In this case, the seismic input is defined by the “elastic response spectrum”. This method may be used if a set of conditions are met, the most important is that the effective damping ratio must not be greater than 30 %.

A more accurate method is a nonlinear time history analysis where all relevant nonlinearities of the structure and seismic protection system are considered in the modelling. In this case, the seismic input is defined by a set (at least 7, better 20) of ground acceleration time histories, commonly denoted as accelerograms. To conduct a nonlinear time history analyses the following data are required:

## >> Structural data

Structural drawings, cross sections of the bridge or building structure, moment of inertia, torsion constant, shear stiffness, materials (modulus of elasticity, shear modulus, density, etc.), foundation (dimensions, Winkler - modulus, etc).

## >> Earthquake data

Response spectrum, compatible or site-specific accelerograms, loads under seismic conditions, allowable bending moments, shear and axial forces, displacements and any further specific requirements of the designer.

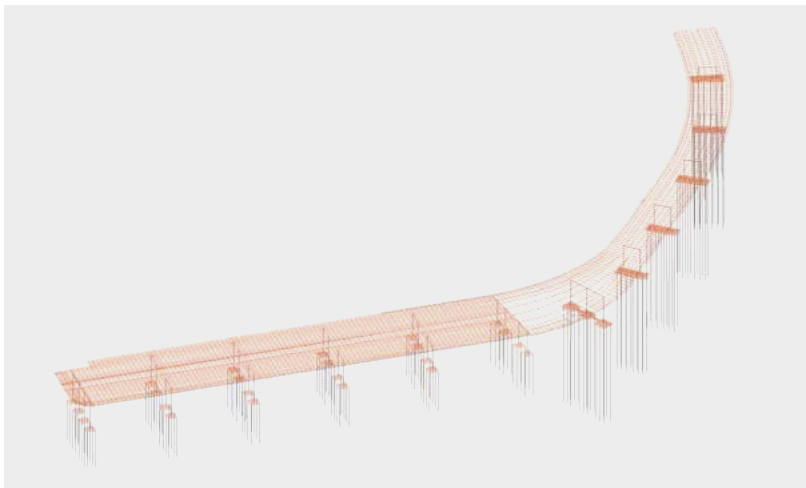

Axonometric view of a rail-way bridge, 3D mathematical model

## >> Benefits of MAURER Nonlinear Structural Analysis

- Optimization of seismic protection system in terms of efficiency and economy.
- Precise evaluation of actual safety margins within the structure and the seismic devices.
- Evaluation of considerable structural cost savings based on less reinforcement and saving steel and concrete.
- Validation of designer's analysis through the numeric analysis by MAURER.
- Accurate prediction of shear forces acting on the isolators and the entire structure.
- Precise evaluation of the isolation system's re-centring capability.
- Accurate determination of structural drifts and torsional effects.

# Structural protection through two basic concepts of seismic protection

Having specified the structural protection required, the seismic engineer evaluates the most reasonable seismic protection strategy considering the characteristics of the structure, the site-specific ground motion data and respecting the European Standards or other seismic codes. Today, seismic engineers can rely upon numerous technical solutions based on various types of well-established strengthening methods and anti-seismic devices:

>> 1. Provide the structural members with adequate flexibility, strength and ductility to reduce displacements by their stiffness and dissipate energy through plastic deformation; these solutions are referred to as “strengthening” or “conventional design” approaches.

>> 2. Protecting the structure against earthquake-induced damage by limiting the seismic effects through the use of devices properly inserted into the structure; these devices are referred to as “anti-seismic devices”.

>> The flowchart below places into perspective the two basic concepts of structural protection against earthquake damage and shows the associated types of anti-seismic devices.

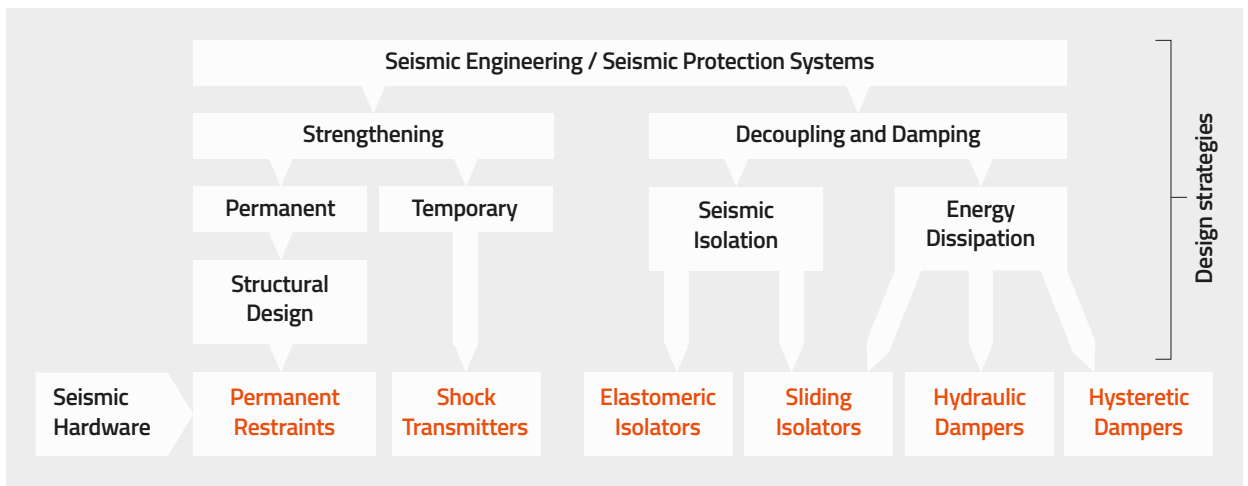

## >> Strengthening

The design engineer who has selected the adoption of traditional techniques – essentially strengthening the structure – has the choice of two approaches:

>> 1. Fit the structure with permanent restraints only, proportioning its structural members with adequate flexibility, strength and ductility.

>> 2. Insert at appropriate locations within the structure temporary restraint devices, which allow slow thermal movements and lock-up for dynamic earthquake events.

The superior seismic behavior of hyperstatic structures, and in particular bridges, is well known. The reason for this fact is that in hyperstatic structures all structural members are forced to work together at a critical moment. However, especially in the case of bridges, construction techniques such as the use of prefabricated beams and the possible differential settling on the foundations lead to the choice of isostatic arrangements. The advantages of the two concepts can be maintained through the adoption of hydraulic Shock Transmitters.

## >> Decoupling and Damping

In the flowchart the alternative to structural strengthening is structural Decoupling and Damping, which is the most effective method to protect structures from the hazardous impact of earthquakes. The latter can be obtained through:

- >> Seismic Isolation,
- >> Energy Dissipation, or better, a
- >> combination of both

Seismic Isolation is by far the most commonly used approach to significantly reduce the structural response due to seismic excitation. A proper isolation system must be capable of appropriately ensuring the following four main functions:

- >> Vertical load transmission
- >> Lateral flexibility (decoupling + period elongation)
- >> Energy dissipation (damping)
- >> Re-centring capability

In addition, the isolation system shall provide a defined minimum base shear as a locking force against non-seismic forces, e.g. wind forces.

Some types of isolators intrinsically possess this function; for others, one must resort to the so-called "Fuse Restraints". MAURER has developed several types of both mechanical and hydraulic Fuse Restraints.

If the adoption of Seismic Isolation is not feasible and the structure possesses sufficient flexibility, i.e. important relative displacements occur during an earthquake due to elastic deformation of its structural elements, then Energy Dissipation (Damping) can be effectively used to attain Seismic Mitigation. This is achieved through the adoption of Hysteretic Dampers



©KSP Jürgen Engel Architekten, Krebs & Kiefer International

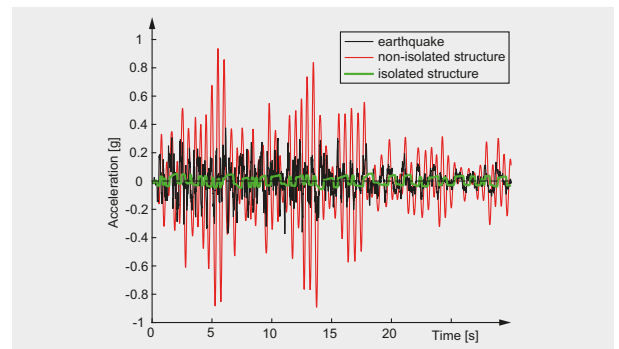
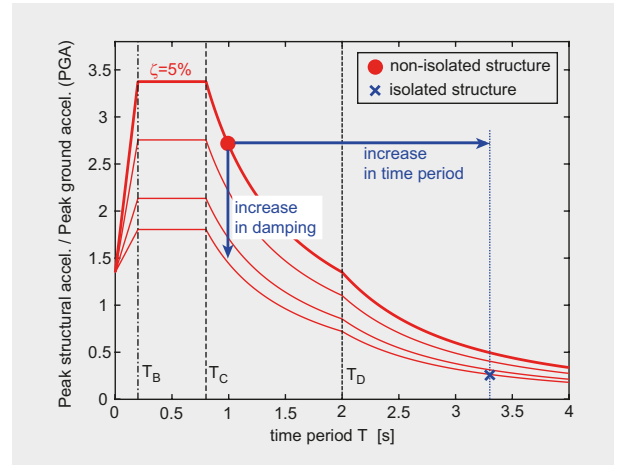

Comparison between accelerations of non-isolated and isolated structures

or Hydraulic Dampers, which are installed in the structure at appropriate locations. Skilled MAURER engineers are available to assist designers in choosing the most appropriate Seismic Hardware on a case-by-case basis, as well as optimizing the adopted solution in terms of performance, costs, reliability, durability and other project-specific criteria.



Djamaâ El Djazir Mosque, Algiers: base solution by Sliding Isolators (SIP®-A) combined with adaptive Hydraulic Dampers (MHD)

## MAURER Restraint Systems for Strengthening

Russkiy Island Bridge, laterally fixed and longitudinally movable permanent restraint-(HKE)



### >> Permanent Restraints (HK, HKE)

Although permanent restraints are included in the family of the most simple seismic hardware, they comprise a large variety of devices. Thus their standardization is problematic and MAURER has adopted the strategy of a "tailor-made" design according to the specifications given by the designers. These restraints can be designed to laterally fix the structure in X and Y directions up to a certain load (HK device) or guide it in one direction (unidirectional =HKE device) only. Past projects have included restraints capable of design loads of more than 25 MN.

### >> Temporary Restraints, Shock Transmitter (MSTU, MSTL)

Shock Transmitters are devices that allow for movements at low velocities (<0.1 mm/s) without appreciable resistance (1-4%  $F_{max}$ ), but produce larger forces at higher velocities to hold the structure in position without noticeable displacement in the STU (0.5 –3% of stroke capacity in loaded direction).

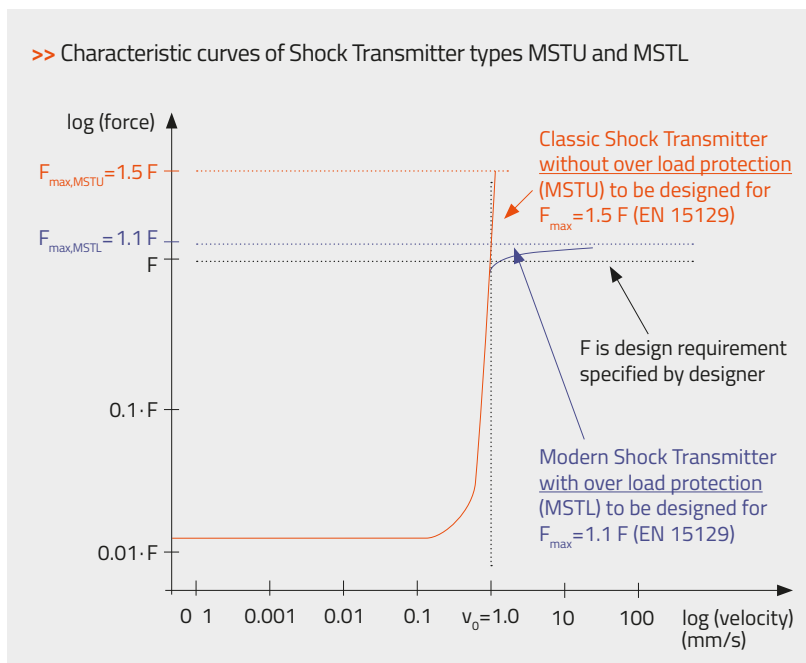

MAURER Shock Transmitters (MSTU) minimize the resistance to thermally induced movements and deformations due to earthquakes because of the adoption of special materials performance, accurate design procedures and proprietary fabrication processes.

The MSTU activation, or lock - up velocity  $v_0$ , is adjusted to the designer's specified value which is typically between 0.1 and 1.5 mm/s but may reach 5 mm/s for very large structures.

The European Standard EN 15129 requires that the reliability factor of Shock Transmitters on their design force  $F$  shall be  $\gamma_x = 1.5$  unless an overload protection system or "force limiter" is incorporated. If a MSTL (shock transmitter with force limiter) is incorporated, the value of the reliability factor can be reduced to  $\gamma_x = 1.1$ . Hence, the adoption of MSTLs decrease the forces acting on the structural members by 27%. It increases the overall safety of the devices and the structure as it is granted that all devices in serial and parallel arrangement are equally

and simultaneously loaded when affected by sudden service or seismic impacts. This is not the case for classic STUs that might be overloaded by a force even greater than 1.5 times the design force  $F$ . Therefore the MSTL application reduces the costs of the structural members and even the cost of the Shock Transmitter itself because MSTLs are more compact than MSTUs. Thus, the MSTL provides not only additional technical benefits and reliability but it also provides the most economical solution.



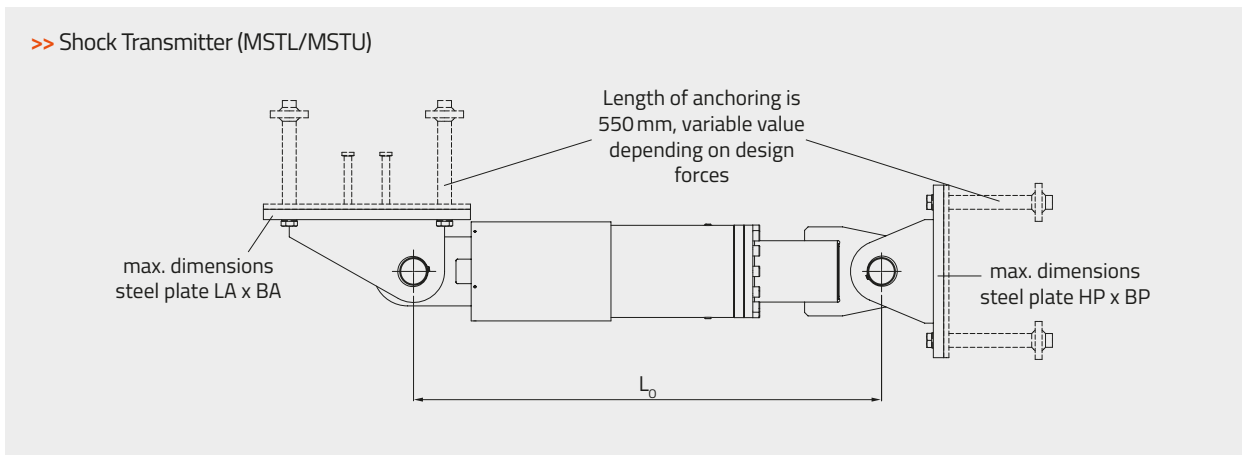

>> Preliminary dimensions based on:

- SLS load duty cycles 100,000 considering  $0.7 \times F$
- Damping exponent  $\alpha = 0.04$  for MSTL
- Adjustable activation velocity  $v_0 = 0.1 - 5 \text{ mm/s}$

MSTU*						
$F_{\max}$	$\pm d_{\max}$	$L_0$	LA	BA	HP	BP
[kN]	[mm]	[mm]	[mm]	[mm]	[mm]	[mm]
750	200	1945	350	335	305	270
1500	200	2075	550	400	400	300
2250	200	2195	635	440	430	400
3000	200	2300	810	460	465	460
3750	200	2525	920	570	515	510
4500	200	2600	1120	585	545	830

MSTL*						
$F_{\max}$	$\pm d_{\max}$	$L_0$	LA	BA	HP	BP
[kN]	[mm]	[mm]	[mm]	[mm]	[mm]	[mm]
550	200	1945	350	335	305	270
1100	200	2075	550	400	400	300
1650	200	2165	625	410	410	400
2200	200	2195	635	440	430	400
2750	200	2300	810	460	465	460
3300	200	2525	920	570	515	510
4400	200	2600	1120	585	545	830
8800	200	3300	1530	940	980	840

$F_{\max}$  = Design force provided by design engineer including reliability factor  $\gamma_x = 1.5$  for MSTU and  $\gamma_x = 1.1$  for MSTL (see EN 15129)

$d_{\max}$  = Maximum seismic displacement

$L_0$  = A function of required  $d_{\max}$

\* Adaption to any specific project is possible

>> Benefits of MAURER Shock Transmitters (MSTU/MSTL)

- Force limiter function for F. Possible overall structural cost reduction in the range of 1–5 % when MSTLs utilized.
- High rigidity with immediate lock-up of structure within maximum 1–3 mm STU relative motion (depends on total stroke).
- Suitable for extreme climate zones.
- Verified by the standard at the place of use, e.g. EN 15129, AASHTO, ASCE.
- Absolutely maintenance-free device.
- Reliability and safety during entire service life.
- No wear and low static friction resistance in the triple-seal-guide system granting at least 50 years of service life without leaking.
- CE-marking is available for all devices.
- Operating temperature range  $-50^\circ$  to  $+80^\circ\text{C}$

# Seismic Isolation

## >> Elastomeric Isolators



Nissibi Bridge,  
Turkey - MAURER  
Lead Rubber  
Bearing (MLRB)

MAURER Elastomeric Isolators decouple structures from their foundations during an earthquake, thereby reducing the seismic impact on the structure. Elastomeric Isolators are well-established bearings that decouple the structure by shear deformation and add damping to the structure by damage-free deformation of the elastomer molecules and/or the lead core. The isolators transfer the vertical loads from the structure to the foundation while at the same time allowing for rotation and elastic re-centring.

### >> Elastomeric Isolator Options:

#### 1. Elastomeric Isolators with Low Damping

##### **MLDRB = Low Damping Rubber Bearing**

These devices are made of several layers of rubber separated by vulcanized steel sheets. The isolation is attained through the shear deformation of the rubber layers. The energy dissipation is poor whereby additional dampers are required to increase structural damping and decrease structural displacements.



Sample of rectangular bearing

#### 2. Elastomeric Isolators with High Damping

##### **MHDRB = High Damping Rubber Bearing**

The different molecular structure of high-damping rubbers (HDR) allows more energy dissipation than for LDRB. This results in effective damping ratios ranging from 6 % to 10 % and therefore a slightly fatter hysteretic loop is obtained. As the energy dissipation is still limited, HDRB are also often combined with additional dampers to reduce structural drifts in case of severe earthquakes.



Test of two connected samples

#### 3. Elastomeric Isolators with Lead Core

##### **MLRB = Lead Rubber Bearing**

To increase the effective damping ratio up to 35%, one or more lead cores are integrated vertically in the elastomeric isolator. When subjected to horizontal deformation, the lead core produces significantly greater hysteretic damping than Low and High Damping Rubber Isolators. The resulting force displacement loop is much fatter, i.e. much more energy is dissipated per cycle, which is the reason why LRBs are the most commonly used Elastomeric Isolators.



Sample of round bearing with lead core

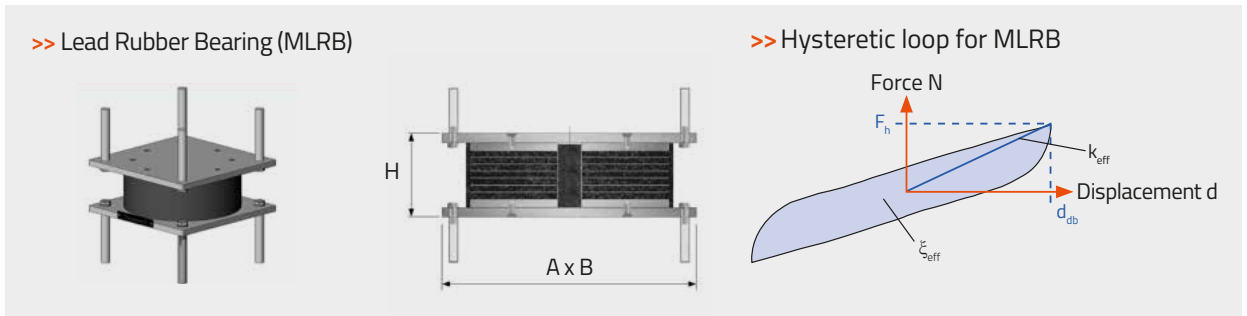

>> Typical parameters:

1. Shear modulus: 0.4 to 1.35 N/mm<sup>2</sup>
2. Effective Damping Ratio: ~5 % to ~35 %
3. Sizes up to: 1,500 x 1,500 x 750 mm, diameter 1,200 x 750 mm

Hospital General Tláhuac, Mexico



>> Preliminary dimensions based on:

- Temperature range: -25 °C to +50 °C for service load case; -13 °C to +45 °C for maximum credible seismic load case
- Total displacement  $d_{max}$  including recommended reliability factors as per EN 1998 ( $\gamma_x = 1.2$  for buildings and  $\gamma_x = 1.5$  for bridges)

Lead Rubber Bearing (MLRB); $d_{bd} = 250\text{mm}$ and $d_{max} = 300\text{mm}$							
$N_{sd}$	$N_{Ed,max}$	$k_{eff}$	$F_h$	$\xi_{eff}$	$T_{eff}$	A,B	H
[MN]	[MN]	[kN/mm]	[kN]	[%]	[sec]	[mm]	[mm]
1,50	1,00	1,87	530	20,7	1,5	500	240
5,00	2,80	3,13	890	20,5	1,9	600	220
7,00	5,00	3,34	946	21,3	2,5	670	250
9,00	6,40	4,02	1128	23,5	2,5	710	270
12,00	8,60	4,45	1251	23,2	2,8	750	270
15,00	10,70	5,14	1444	23,6	2,9	800	270
18,00	12,90	5,08	1426	23,9	3,2	840	290
20,00	14,30	5,62	1570	25,0	3,2	870	290
22,00	15,70	6,28	1754	24,9	3,2	920	310
26,00	18,60	6,57	1837	24,7	3,4	970	330
31,00	22,10	6,42	1794	25,2	3,7	1000	350
37,00	26,40	6,87	1922	24,5	3,9	1070	370
41,00	29,30	7,63	2138	24,4	3,9	1130	370

$N_{sd}$  = Maximum vertical design load combined with service displacements  $d$

$N_{Ed,max}$  = Maximum vertical earthquake load combined with  $d_{max}$

$d_{bd}$  = Seismic design displacement

$d_{max}$  = Total displacement including reliability factor

$F_h$  = Horizontal force

$\xi_{eff}$  = Effective damping for  $d_{bd}$

$T_{eff}$  = Effective periode for  $d_{bd}$

Additional tables with different shear modulus, displacement and loads are available (see at [www.maurer.eu](http://www.maurer.eu), technical information TI\_003).

>> Benefits of MAURER Elastomeric Isolators

- Great durability of high quality MAURER synthetic chloroprene or natural rubber compounds for a life span of 20 to 50 years; less ageing effects by chloroprene rubber compounds.
- Effective Damping Ratio of up to 30–35 % for considerable structural drift reduction.
- Devices extensively tested and available with CE-marking.
- Suitable for “moderate” climate zones with temperatures above 0°C; if used for -25°C the 30–50 % hardening effect of the rubber compound must be considered in the seismic design concept.
- Verified by the standard at the place of use, e.g. EN15129, AASHTO, ASCE.

## >> Sliding Isolators



New Acropolis  
Museum in Athens  
MAURER SIP®

MAURER Sliding Isolators decouple structures from seismic excitation with movement at their sliding surface resulting in small base shear. They remain free of wear even after 3 - 10 design earthquakes whereby their lifespan matches that of the structure they are protecting.

The devices are made of a lower and upper bearing plate with a spherical MSA® sliding lens in between. The sliding liner MSM® is an extremely stress-resistant sliding material patented by MAURER and certified in the MAURER European Technical Approval ETA-06/0131.

MAURER Sliding Isolators are applied in new buildings and bridges as base isolators or are adopted for the seismic retrofitting of existing structures. They can transmit extreme vertical loads, accommodate large lateral displacements, enable rotation, and effectively re-centre the superstructure. Depending on the damping demand, the isolator can be designed with friction between 1 % and 7 % or can be with MAURER Hydraulic /Hysteretic Dampers.

### >> Sliding Isolator Options:

#### 1. Sliding Isolator (SI) without re-centring

These devices have a flat sliding plate that accommodates horizontal displacements and dissipates energy by friction between the MSM® sliding material and the stainless steel sheet.

#### 2. Sliding Isolation Pendulum (SIP®) with re-centring

These devices have a concave sliding plate, thereby working similar to a pendulum, and dissipate energy by friction on the sliding surface. The curvature of the concave plate provides the period and re-centring stiffness which is inversely proportional to the radius of curvature.

#### 3. Double Sliding Isolation Pendulum (SIP®-D) with re-centring

Within these isolators, the sliding lens moves between the two identical concave bearing plates, thereby doubling the displacement capacity compared to the single SIP® of same diameter. Therefore the size of the bearing footprint can be significantly reduced for the same displacement capacity.

#### 4. Adaptive Sliding Isolation Pendulum (SIP®-A) with re-centring

This adaptive isolator generates optimum structural isolation independent of Peak Ground Acceleration of the earthquake, reduces base shear and displacement capacity thanks to its high efficiency and ensures a high rotation capacity.

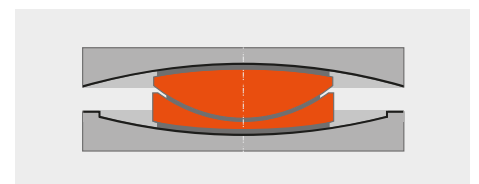
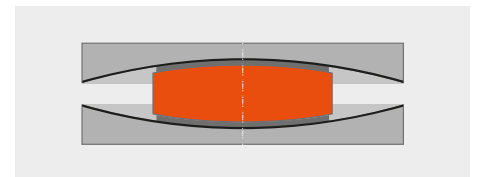
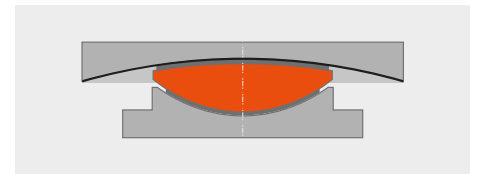
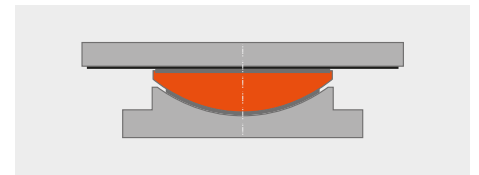

### >> Measured force

Displacement loops of Sliding Isolation Pendulums SIP®-A tested at EUCENTRE, Pavia, Italy

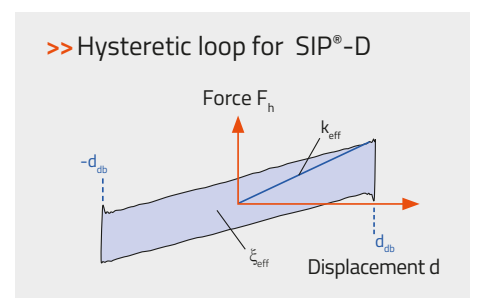
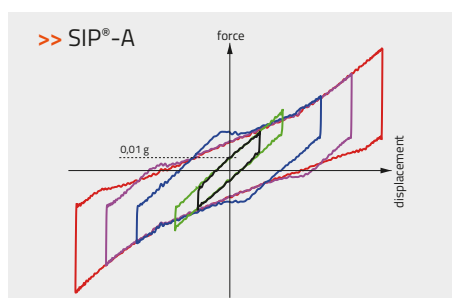

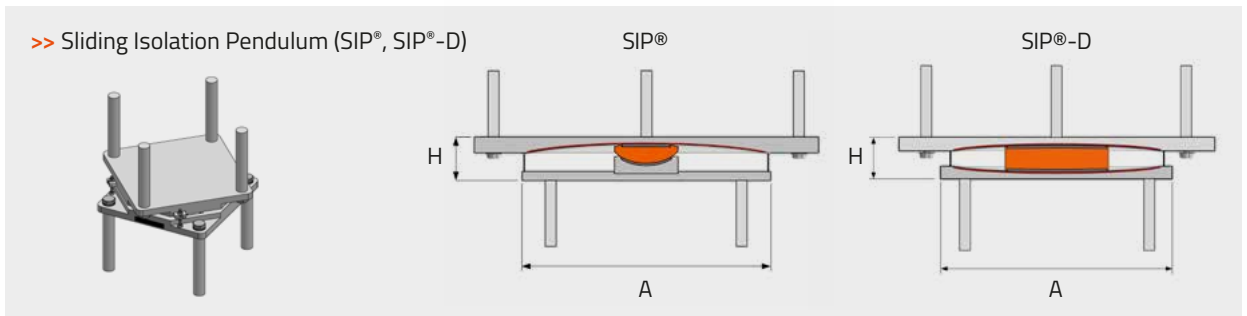

$N_{Sd} / N_{Ed,max}$ [kN]	$d_{max}$ [mm]
500 / 1,000	+/- 350
1,000 / 2,000	+/- 350
2,000 / 4,000	+/- 350
3,000 / 6,000	+/- 350
5,000 / 10,000	+/- 350
7,000 / 14,000	+/- 350
11,000 / 22,000	+/- 350
15,000 / 30,000	+/- 350
25,000 / 50,000	+/- 350
30,000 / 60,000	+/- 350
35,000 / 70,000	+/- 350

SIP®	
Plan view A*	Height H**
[mm]	[mm]
820	155
880	165
940	175
990	185
1,085	190
1,160	200
1,260	215
1,360	240
1,560	295
1,620	325
1,710	365

SIP®-D	
Plan view A*	Height H**
[mm]	[mm]
530	125
580	135
650	150
710	165
790	200
860	230
980	280
1,080	330
1,250	420
1,310	485
1,410	550

$N_{Sd}$  = Seismic weight in non-seismic design situation  
 $N_{Ed,max}$  = Maximum vertical load in seismic design situation  
 $d_{max}$  = Total displacement for earthquake combined with service condition (thermal/wind/creep/shrinkage)

\* Based on assumption of 3% dynamic friction for  $N_{Sd}$   
 \*\* Based on assumption of 4,000 mm pendulum radius; without anchoring measures; depending on specified concrete compression stresses

Adaption to any specific project is possible

>> Remarks

The dynamic coefficient of friction, pendulum radius and bearing displacement will be adapted individually to the structure depending on the maximum allowed base shear and displacement. Bearings can be designed for loads up to 250 MN or even more.

Hotel Secrets & Dreams Bahia Mita Mexico, MAURER SIP®-D



>> Benefits of MAURER Sliding Isolators

- MAURER Sliding Isolators are absolutely maintenance-free and can provide 50-150 years of service life.
- Immediate smooth displacements without stick-slip effects as static friction values are low.
- MSM® liner material exhibited no signs of aging or wear after 50 km of static and dynamic sliding travel during tests conducted at University of California San Diego, USA and Material Test Institute University of Stuttgart! Continued functionality is guaranteed even after 3 - 10 design earthquakes.
- Specific isolation time period as the period of a pendulum does not depend on the vertical load.
- The design, MSM® liner material, checking and testing provisions approved by official state approval (ETA) together with CE-marking provide reliability and safety.
- Operating temperature -50 to +70 °C.
- Verified by the standard at the place of use, e.g. EN15129, AASHTO, ASCE.

# Energy Dissipation

## >> Hydraulic Dampers (MHD)

MAURER Hydraulic Dampers (MHD) can complement isolators and structural bearings to achieve a superior system behaviour in terms of reduced forces and displacements for seismic as well as service load cases. They guarantee maximum damping and controlled energy dissipation. During an earthquake, an intelligent fluid flow control system permits relative motion and keeps the response force at an almost constant level. On request the devices can be fitted with low friction (< 1% of F) and frictionless (> 450 km sliding path) seal systems.

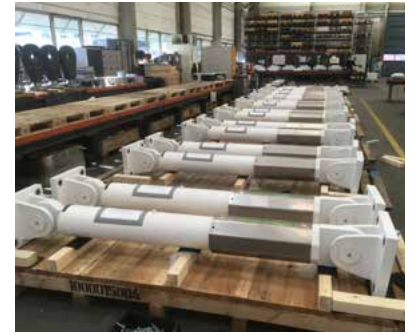

Assembled hydraulic dampers

### >> Functional performances

**A) Service load for temperature movements:**

No significant response forces greater than 1–3% of F for velocities lower than 0.1 mm/s.

**B) Shock load (traffic, wind, earthquake):**

Sudden reaction force starting from velocity  $v_0 = 0.1$  to 2 mm/s to block impulse actions from wind and traffic while minimising structural movements resulting from these service load cases. Reaction behavior can be adapted in term of velocity and stiffness.

**C) Earthquake:**

The damper allows relative motion at high forces and thereby dissipates great amounts of energy. The max. response force  $F_{max}$  is almost independent of velocity within the velocity range from  $v_d$  to  $1.5 v_d$  – the so-called over velocity acc. to EN 15129. As a result, the MHD, its anchoring and the structure are protected against overloading.

**>> Force velocity diagram of a MHD**

Damper design force  $F_{max}$  including reliability factor  $\gamma_v$  for 150% over velocity and reaction tolerance due to production acc. to EN 15129

### >> Building damper



Typical building damper

Building dampers			
$F_{max}$	$\pm d_{max}$	$L_0$	$\varnothing D$
[kN]	[mm]	[mm]	[mm]
500	50	670	370
1000	50	670	370
1500	50	740	430
2000	50	740	480
2500	50	920	540
3000	50	1070	680
4000	50	1180	750

**>> Measured force displacement curve of a MHD with  $F_{max} = 1,900$  kN and 1,300 mm total stroke capacity tested with harmonic displacement input at Ruhr-University Bochum, Germany**

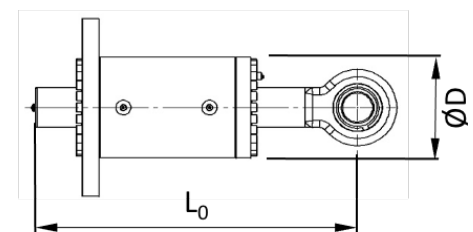
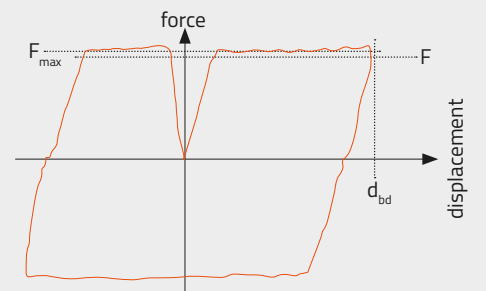

Adaption to any specific project is possible

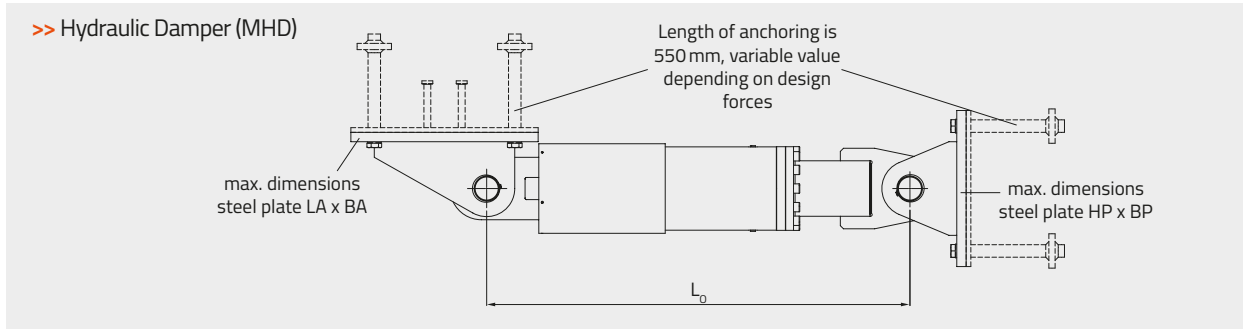

>> Preliminary dimensions based on:

- Max. velocity  $v = 300$  mm/s can be to 1,500 mm/s or greater
- $F_{max}$  is not significantly greater than  $F$
- Frequently occurring service forces due to traffic, wind, etc.:  $F_{service} = 0.25 \times F_{max}$  200,000 load cycles considered  $F_{service}$
- Damping exponent  $\alpha = 0.04 \rightarrow$  can be modified as necessary to linear viscous behaviour ( $\alpha = 1$ ) and/or even hybrid damping exponent functions are achievable
- Over velocity and manufacturing tolerances are considered acc. to EN 15129 for  $F_{max}$  with reliability factor  $\gamma_v = (1 + t_d) \times 1.5^\alpha$  which is multiplied with designer's force specification  $F$  and  $t_d = 0,1$  for reaction tolerance

Hydraulic Damper (MHD)						
$F_{max}$	$\pm d_{bd}$	$L_0$	LA	BA	HP	BP
[kN]	[mm]	[mm]	[mm]	[mm]	[mm]	[mm]
585	200	1945	350	335	305	270
1200	200	2075	550	400	400	300
1750	200	2165	625	410	410	400
2350	200	2195	635	440	430	400
3000	200	2300	810	460	465	460
3500	200	2525	920	570	515	510
4700	200	2600	1120	585	545	830

$F_{max}$  = Maximum force without reliability factor  $\gamma_v$  of 150 % on velocity

$d_{max}$  = Maximum seismic displacement

$L_0$  = In accordance with chosen  $d_{max}$

Custom designs to meet additional service requirements available upon request.

>> Benefits of MAURER Hydraulic Dampers MHD

- No leaking due to the triple-seal-guide system avoiding wear and fatigue (tested for 400 km).
- Protection of device and structure by effective force limiter function with special valve system.  $F_{max}$  is larger than  $F_d$  based on typical  $\gamma_u$  in range of 1.07 to 1.12 with production tolerances ( $t_d$ ) of 0.05-0.10.
- Optimum performance in any climate zone.
- Functional characteristics virtually independent of temperature within -50 to +80 °C.
- Immediate lock-up after max. 1-3 mm displacement
- for service loads resulting from low compressibility (only 0.5 to 3 %) of the hydraulic oil.
- Smaller displacements and forces within the system with damping exponents  $\alpha = 0.04$  to 1.0 . Hybrid systems consisting of various exponents for the associated velocity ranges are possible.
- Optimized design with CE-marking.
- MAURER can provide adaptive dampers (MHD-A) especially addressed to the needs of stay cables and tuned mass dampers.
- Service life of more than 50 years.
- Verified by the standard at the place of use, e.g. EN15129, AASHTO and ASCE.

## Steel Hysteretic Dampers (MSHD)

The devices of the MSHD family are classified as displacement dependent devices (DDD) and a non-linear devices (NLD) according to EN 15129 with axial operation direction. MAURER has developed and experimentally verified two types of dampers. The Long-Stroke Hysteretic Dampers (LSHD) named MANTIS® are usually installed on bridges and the Short-Stroke Hysteretic Dampers (SSHD) named SHARK® within buildings.



MAURER SHARK®-Adaptive

Both damper types dissipate seismic energy by plastic deformation of steel elements to effectively increase system damping and decrease force levels. Frequent service loads will be transmitted within the elastic range of the devices and the fatigue behaviour will be checked according to EN1993-1-9 or other standards.



MAURER MANTIS®

### >> Benefits of MAURER Steel Hysteretic Dampers

- Very effective decrease of force and displacement independent of temperature and imposed velocity.
- Lifetime of 100 years or more without maintenance as no ageing, wearing or contamination can occur.
- After shock functionality provided since 2-4 MCE events can be accommodated without damage or failure.
- Easy visual inspection and function check after earthquakes are possible.
- CE marking and certification available upon request.
- Modular serial or parallel arrangement of devices possible to achieve the required energy dissipation.
- Very cost effective due to simple compact design with steel elements.
- Optional MAURER Monitoring System is available.



## >> MANTIS® – Long-Stroke Hysteretic Damper (LSHD)

The MANTIS® damper is optimized to provide fully symmetrical force displacement loops for multi-span bridges or isolation systems up to +/- 410 mm displacement. This allows reliable displacement control and force mitigation. The device is particularly suitable for systems experiencing not more than +/- 15 mm to +/- 25 mm of frequent service (e.g. thermal) movements. Therefore the optimal installation location of the device for longitudinal displacements is the bridge centre span or the abutment for shorter bridges. In lateral bridge direction the MANTIS® can be even placed on any axis.



>> Characteristic curve of MANTIS®

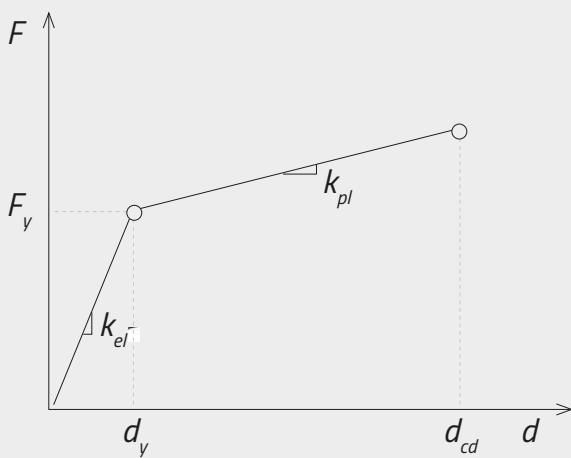

>> Hysteretic loop of MANTIS®

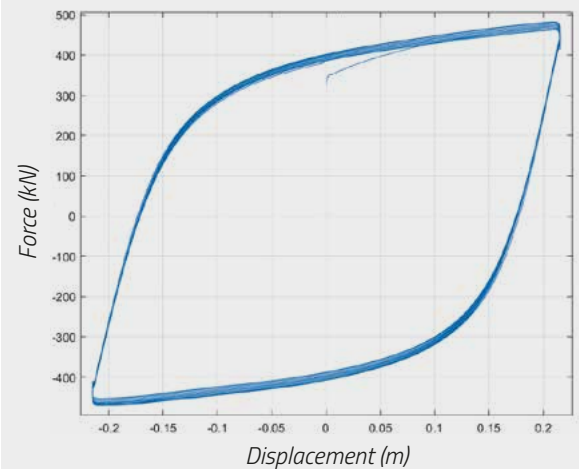

### >> Benefits of MAURER MANTIS®

- Effective protection of structure as seismic force levels are reduced by a factor of two to five.
- The remarkable second branch stiffness provides a significant contribution to the re-centering of the structure – see curves.
- Displacement capacity up to +/- 410 mm is possible.
- Main applications are bridge decks or secondary damping with seismic isolation systems.

## >> SHARK® – Short-Stroke Hysteretic Damper (SSHD)

The SHARK® damper is an innovative energy dissipation device capable of providing absolute structural safety and avoiding potential earthquake induced damage. These dampers are mainly considered to be a part of the structural bracing system within building or high rise structures. The Shark damper is made of steel with special lamellas providing shear yielding response characteristics.

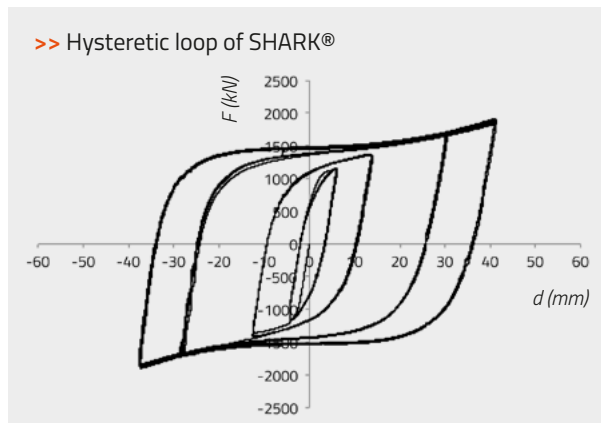
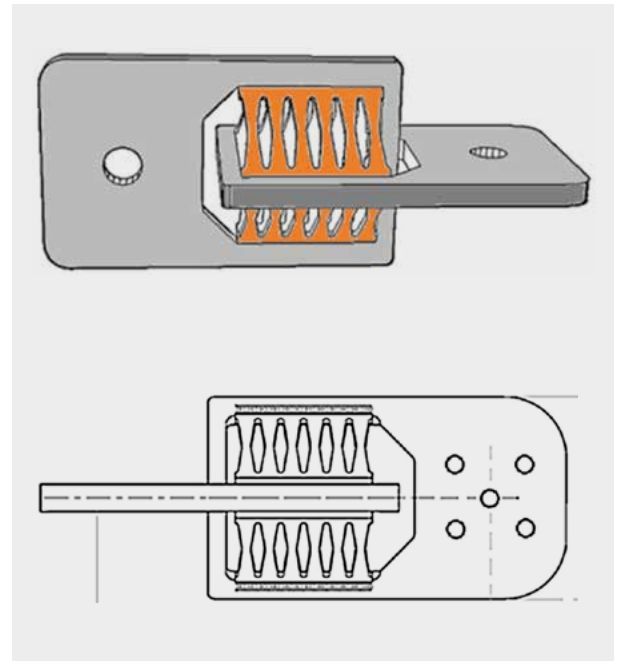
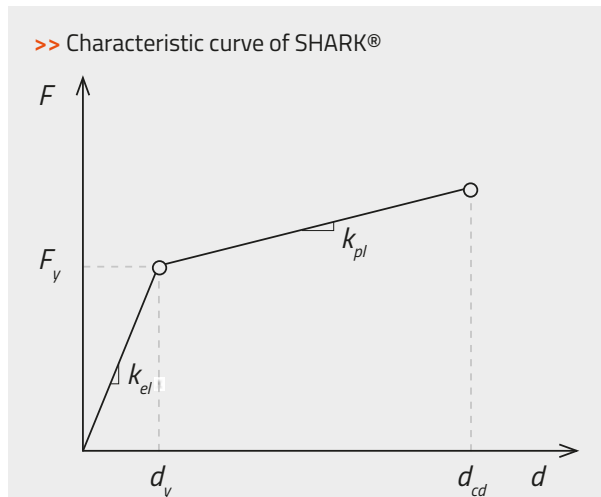

### >> Benefits of MAURER SHARK®

- Redundant parallel arrangement of the hysteretic lamellas provides great reliability and safety.
- Designed for the maximum credible earthquake event.
- Reliable structural drift control while reducing seismic forces by a factor of two to four.
- Displacement capacity up to +/- 70 mm or more.
- Simple modelling with a bilinear hysteretic loop.
- Main applications are building bracing systems.

## >> SHARK®-Adaptive – Short-Stroke Hysteretic Damper (SSHD)

The SHARK®-Adaptive damper features an unique “two stage” hysteretic loop that allows for flexible adjustment of effective stiffness and damping based on the intensity of the earthquake. For weak but frequent design earthquakes the device is quite adaptive and offers minor, but adequate, energy dissipation. This behaviour minimizes peak floor accelerations for effective protection of sensitive non-structural components of the building (e.g. elevators, electric panels, false ceilings, medical equipment).

During strong MCE events the device suddenly stiffens achieving a much higher damping force with the aim to limit the maximum structural drift ratio. The two dissipative cores are arranged in series and are linked with a “gap-connector plate”. For small displacements ( $|d| \leq d_{GAP}$ ), the minor dissipative core (green; regime 1) is activated first in its elastic and then plastic regime to increase the structural damping. During these small displacements, the major core (orange) remains in the elastic range. For bigger displacement amplitudes ( $|d| > d_{GAP}$ ), the major hysteretic core (orange; regime 2) becomes engaged and offers a higher effective stiffness and damping.

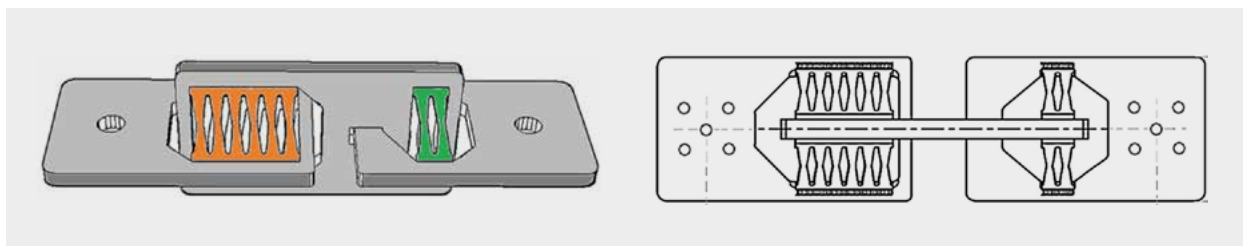
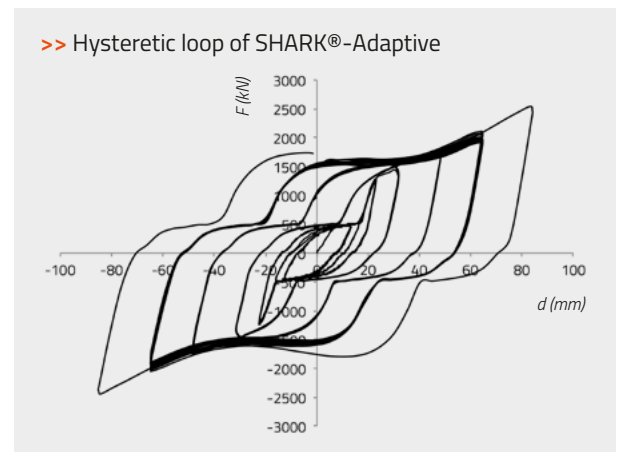
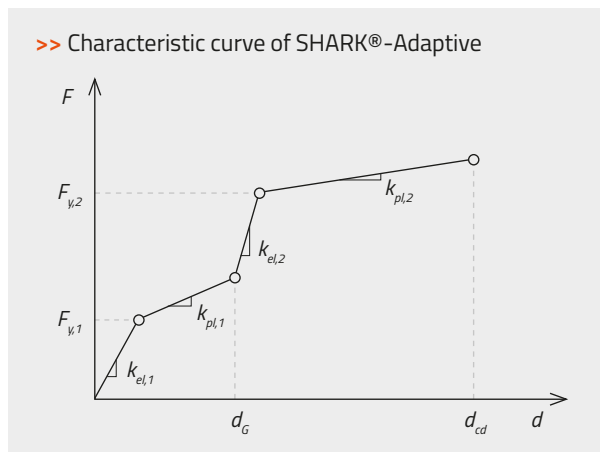

### >> Benefits of MAURER SHARK® -Adaptive

- Similar to SHARK®, however with customized and optimized behaviour providing additional protection of sensitive non-structural components and technological content of buildings that are required to remain fully operational in the emergency response after an earthquake.
- Seismic force reduction by a factor of two to six.
- Displacement capacity up to +/-120 mm or more.
- Main applications are building bracing systems.

## MAURER Seismic Expansion Joints

All expansion joints in road and railway bridges must to accommodate movements and rotations between the adjacent structures while simultaneously transferring traffic loads and forces. Expansion joints must be designed to handle multiple degrees-of-freedom movements provided by the structural bearing system as well as service, extreme limit state and seismic load conditions. Key influencing parameters for service movements are temperature fluctuations, creep/shrinkage of the concrete and imposed loads such as wind and traffic. Seismic effects generate additional, in some cases significant, deflections and displacements that often deviate considerably in terms of intensity, direction and velocity from the service condition. During a seismic event it is essential that joint systems remain structurally stable and after a seismic event they should be fully operable or must at least enable restricted traffic for security and rescue services.

### >> Benefits of MAURER Seismic Expansion Joints

- Emergency vehicles can immediately pass over the joints after a seismic event.
- Depending on the project specification requirements, the amount of damage caused by large seismic displacements is variable – no damage or limited damage while immediate overpassing of the joint for emergency vehicles is usually always a MUST.
- Fuse Box-Systems provide a more economical design combined with quick repair procedures.
- Service life of 20-50 years or more is possible due to fatigue resistant design and incorporation of durable materials and details.

### >> MSM® Swivel Joist Expansion Joint for Road Bridges

MAURER MSM® Swivel Joist Expansion Joints are particularly suited for large and complex structural movements. Due to the freedom of movement of each individual centre beam, total movements of the expansion joint in the longitudinal direction of 3.5 m or more can be accommodated without damage during the earthquake. By controlling each individual centre beam separately, very large longitudinal service movements can be accommodated at the same time as lateral bridge movements of up to  $\pm 2.5$  m. Various movement combinations which can be accommodated by a MAURER MSM® Seismic Swivel Joist Expansion Joint are illustrated below while looking onto the joint:

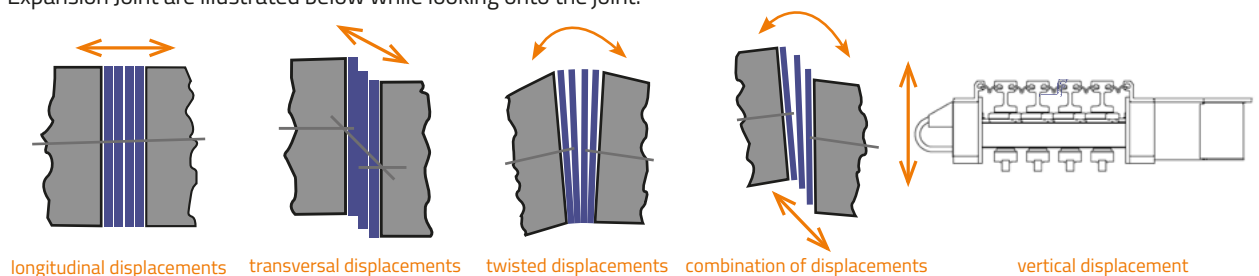

View of support bar

### >> Fuse Box Systems for modular joints

In situations where it is decided to not accommodate all of the seismic displacement by the centre beams of the Swivel Joist or any other modular expansion joint type, the MAURER Fuse Box System should be considered. The Fuse Box System is designed to allow seismic movements from smaller earthquakes while accepting limited damage to the joint system if this displacement is exceeded in a larger earthquake. The concept behind the MAURER Fuse Box System is to protect the bridge deck from high compressive stresses and damage when the bridge structure closes more than the space available in the gaps between the centre beams.

In general two MAURER Fuse Box Systems are available for Girder Grid and MSM® Swivel Joist Expansion joints:



Joint with Fuse Box System type IV

### >> Longitudinal Fuse Box System

#### Type I/III:

For the design of the longitudinal Fuse Box System it is important to know the maximum opening and closing movements of the expansion joint. For large seismic joint opening movements the gaps between centre beam may open more than 150 mm. For large seismic closing movements resulting in the joint fully closing and contact of all centre beams, the longitudinal Fuse Box System will be released to prevent the expansion joint from being crushed between the bridge deck and abutment or transition pier.

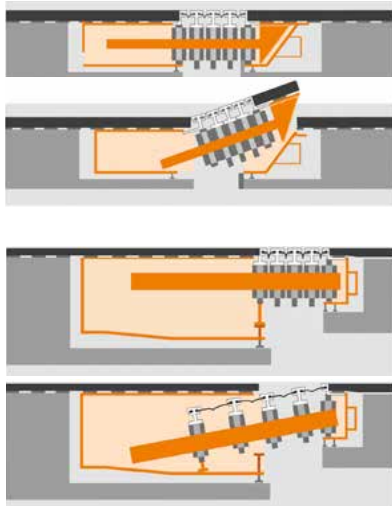

#### Type I:

During large closing movements, one expansion joint side is pushed upwards via an inclined steel box. The safety mechanism is activated by intentional failure of welded joints at specific points.

#### Type III:

On one side, the expansion joint drops down into a prepared space of the Fuse Box. There it can perform movements exceeding the maximum closing movement. The safety mechanism is activated by intentionally failing bolted connections near the carriageway surface and at the bottom of the joint where it connects to the structure. This fuse type reduces damage to the top of the roadway and allows for better passing ability in the released position. Normal movement capacity is guaranteed during aftershocks.

### >> Lateral Fuse Box System

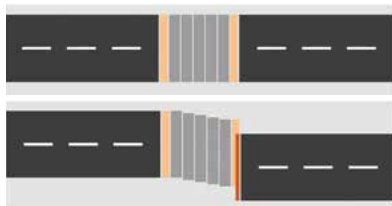







#### Type IV:

As soon as the bridge movements in the transverse direction exceed the movement capacities of the joint, the failure of a notched steel pin activates a sliding guide system. This allows the complete joint to move laterally in a sliding movement without damaging structural elements of the joint.

Fast and simple repair of the expansion joint and adjacent bridge deck, i.e. small welds, bolted connections and asphalt repair work, is possible.

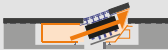
>> Available Seismic Expansion Joint types with and without Fuse Box Systems:

	Railway	Roadway			
	Guided Cross Tie	Swivel Joist Expansion Joint without Fuse Box	MSM® Swivel Joist Expansion Joint with Fuse Box		
Characteristics			Type I	Type III	Type IV
Before earthquake	Unchanged condition after earthquake	Unchanged condition after earthquake			
After earthquake					
Traffic safety during earthquake	++++	++++	++	+++	+++
Condition after DBE	++++	++++	+++	++++	++++
Condition after MCE	++++	++++	++	+++	+++
Passing over of rescue vehicles after earthquake DBE, MCE	++++	++++	++	+++	+++



15 Temmuz Şehitler Köprüsü, Turkey



Type I Fuse Box System

### >> Guided Cross Tie for railway bridges

In railway bridges, deck movements occurring between superstructure units lead to additional track tension and stresses on the rail anchorage. With the Guided Cross Tie expansion joint a bridging system has been developed which ensures that the sleeper spacing does not exceed the permissible value while accommodating all regular and earthquake structural movements (displacement in X-,Y- and Z-direction, torsion, twisting) without causing any damage within the joint. The control principle of the well proven roadway MSM® Swivel Joist Expansion Joint was successfully adapted to fulfil all requirements for railway traffic, too! The Guided Cross Tie is positioned in the joint recess prepared on site and monolithically connected to the structure by a concrete closure pour. Alternatively the joint can be installed onto regular ballast.



Railway line from Mexico City to Toluca, Mexico



### >> Benefits of MAURER Guided Guided Cross Tie:

- Accommodates multi-directional seismic movements without damage.
- Effective derail protection mechanism can be integrated when required.
- Design for longitudinal service and seismic movements of 1600 mm or more.
- Designs available for light rail, regular rail or cargo rail systems.
- Can accommodate axle loads up to 250 kN and overpassing velocities of 300 km/h or more depending on design requirements.
- Service life of 20 years or longer due to fatigue-resistant design and durable watertight sleeper seals. No planned regular maintenance work is necessary.
- Excellent travel comfort for overpassing train traffic.
- Quick and easy installation within 1-2 days.
- Easy and quick inspection without interrupting train traffic. Inspection and any maintenance work can be done from below the joint.

## >> Type designation plate

All important data of the bearing assembly are shown on the type designation plate which is attached to each device.



Typical designation plate without CE-marking



Typical designation plate with CE-marking

### >> MAURER type designation plate

 MAURER SE Frankfurter Ring 193 80807 Munich, DE	TYPE [ 1. ]	$N_d$ [ 5. ]	kN ST [ 9. ]	12.
	LOC [ 2. ]	$V_{xd}/V_{yd}$ [ 6. ]	kN ST [ 10. ]	
	O-NO [ 3. ]	$V_{xd}/V_{yd}$ [ 7. ]	mmST [ 11. ]	
	C-NO [ 4. ]	$\phi_{xd}/\phi_{yd}$ [ 8. ]	mrad [ ]	13. ] YEAR [ 14. ]

- |                          |  |   |
|--------------------------|--|---|
| 1. Device type           | 6. Max. horizontal force                 | 11. Standard No.  |
| 2. Installation location | 7. Max. displacement along x- and y-axis | 12. CE-marking (if applied)                             |
| 3. Order No.             | 8. Max. rotations around x- and y-axis   | 13. Certificate No. (cert. of constancy of performance) |
| 4. Article No./ ID No.   | 9. Standard No.                          | 14. Manufacturing year                                  |
| 5. Max. vertical load    | 10. Standard No.                         |   |

## >> Testing

The components for seismic protection can be tested according to EN 1337, EN 15129, AASHTO or any other specified standards.

Tests of seismic devices can be performed at following test institutes:

- University of the Federal Armed Forces in Munich / Germany
- Ruhr-University in Bochum / Germany
- EUCENTRE at the University of Pavia / Italy
- ISMES in Bergamo / Italy
- POLITECNICO in Milano / Italy
- University of California, San Diego / USA
- University of California, Berkeley / USA



## >> MAURER Monitoring System (MMS)

MAURER Monitoring Systems can be applied for product and structural monitoring as well as for continuous recording of structural effects. Their objective is to ensure the functional efficiency, traffic safety and economic operation of a structure over its service life. In addition, it is providing important data if systems perform correctly or not.

### >> Benefits of MMS

- Improved risk analysis over the service life.
- Assessment of condition and functionality.
- Extension of service life through defined repair measures.
- Basis for recalculation and engineering tests.
- Monitoring of local damage.
- Support of the building inspection with additional relevant information.
- Comparison of actual behavior with calculated values and models.



### >> Quality control

Partial list of fulfilled technical standards and assessments:

- EN 15129 "Anti-seismic devices"
- EN 1998-1 "Design of structures for earthquake resistance – General rules, seismic actions and rules for buildings"
- EN 1998-2 "Design of structures for earthquake resistance – Bridges"
- EN 1337 "Structural bearings"
- DIN EN ISO 9001 "Quality management systems"
- EN 1090 "Execution of steel structures and aluminium structures"
- DIN EN ISO 14001 "Environmental management systems"
- CE marking
- European Technical Approval ETA-06/0131 "Spherical and cylindrical bearing with special sliding material made of UHMWPE (Ultra high molecular weight polyethylene) with trade names MAURER MSM® Spherical and Cylindrical Bearing"
- Testing by independent universities and notified bodies



## Individually adapted testing of seismic devices

On request MAURER will do static and dynamic testing on any seismic device according to the required standards. It is important to test not only for ultimate seismic load cases but also, if relevant, for the structure, consider frequently occurring service load cases such as wind, braking of railway, traffic loading vibrations, etc.

The seismic testing is finally confirming the capability of energy dissipation with its upper and lower bounds, the stiffness, the stability and integrity of the device, and the durability that even after more than five design earthquakes MAURER devices do not suffer of any damage.

The aim of testing for service load condition is more related to the proof of wear resistance (at least 10,000 m sliding test for thermal or traffic displacements), fatigue resistance (up to several million load cycles of wind loading), initial high stiffness resistance to lock-up for service impact loadings (railway, wind, etc.) and general durability.

### >> Atomic Power Plants and Wind Parks/Europe

Tests at University of Armed Forces Munich/Germany of structural rubber isolators for 900 kN to 6,590 kN service load capacity, lateral displacements up to +/- 120 mm and 2 mm to 15 mm vertical displacement with at 0.04 Hz to 1 Hz.



### >> Incheon Airport Project/Korea

Test at EU Center University Pavia/Italy of SIP® pendulum isolator for 35,000 kN load capacity, +/- 200 mm and 0.175 Hz for seismic application in an access bridge.



### >> Russkiy Bridge Project

Test at CALTRANS University of California San Diego/USA of MHD damper for 3,000 kN service and up to 5,000 kN ultimate force, 800 mm stroke, -40 °C and up to 750 mm/s as the application is for service wind and ultimate seismic load conditions with low temperature requirement.



### >> Axios Railway Bridge Project/Greece

Test at Ruhr-University Bochum/Germany of MLRB lead rubber bearing for 22,000 kN load capacity, +/- 260 mm and 250 mm lead core diameter inside for great energy dissipation capacity during seismic load conditions.



## MAURER systems are as individual as the structures they protect

### >> Russkiy Bridge in Vladivostok / Russia

**Task:** Structural protection against wind and earthquakes on what is currently the widest spanning cable-stayed bridge in the world with a pylon distance of 1,104 m.

**Scope of the project:** Swivel Joist Expansion Joints of 2.4 m movement (XLS 2400), MAURER MSM® spherical (KGA, KGE) and horizontal force (HKE) bearings with 34 MN superimposed load, plus 25 MN horizontal force, hydraulic wind/earthquake dampers (MHD) for 3MN and 2.2 m of movement, passive and adaptive cable-stayed dampers for cables up to 578 m length.



### >> New Acropolis Museum in Athens /Greece

**Task:** Structural isolation to protect this 33,000 tonne new building against earthquake damage.

**Scope of the project:** MAURER MSM® Sliding Pendulum Bearings with an upper Sliding Plate (SIP®) for up to 13.6 MN of superimposed load and +/- 255 mm of movement.

### >> Las Piedras railway viaduct near Malaga /Spain

**Task:** The Spanish high-speed train AVE generates braking forces in the 1,200 m long viaduct, which must not cause any significant structural movements. In addition, the 93 m tall and flexible piers are subjected to considerable stress during earthquake of 0.1g - 0.2g.

**Scope of the project:** MAURER MSM® Spherical Sliding Bearings (KGA, KGE, KF) for up to 25 MN of superimposed load, 2 MN of lateral force and +/- 350 mm of movement. Hydraulic Dampers (MHD) for 2.5 MN, plus +/- 350 mm of movement with shock transmitter and load limiter function (MSTL) for traffic loads.



>> Djamaâ El Djazir Mosque in Algiers /Algeria

**Task:** The maximum peak ground acceleration on the 145 m long, 145 m wide and 65 m tall main building is 0.65 g. Even at this acceleration, the structure and its contents must not sustain any significant damage.

**Scope of the project:** MAURER MSM® Sliding Pendulum bearings with two sliding plates and rotational hinge (SIP®-A) for up to 27 MN and +/- 655 mm of movement; Hydraulic Dampers (MHD) for 2.5 MN, plus +/- 655 mm of movement.



>> Nissibi Bridge / Turkey

**Task:** The 610 m long bridge is to be placed on elastic/floating bearings for service and earthquake load cases. The temperature fluctuations must also be distributed evenly across the structure and the maximum movement amplitudes limited in the event of an earthquake.

**Scope of the project:** MAURER Lead Rubber Bearings (MLRB) for up to 31 MN of superimposed load and +/- 380 mm of movement.

>> Butterfly Towers of Bucharest / Romania

**Task:** Structural protection against wind-induced vibrations due to strong vortex shedding at the building edges that interfere with occupant comfort. Moreover, Bucharest is situated in a seismic area in which – without damping of the upper stories – building vibrations of more than 500 mm would occur.

**Scope of the project:** 56 MAURER dampers (MHD) for building protection. The dampers feature a damping exponent of 0.15, defining the force output of the damper depending on the movement velocity. In case of an earthquake, 32 dampers for the higher office tower respond with 1,550 kN at velocities of 191 mm/s and ±90 mm amplitude. The 24 smaller dampers at the south tower are designed for 1,170 kN at 191 mm/s and ±75 mm amplitude. Both types of dampers have a length of 750 mm.





>> Hospital General Tláhuac – first hospital with seismic isolation in Mexico City/Mexico

**Task:** The new hospital was built in the outskirts of Mexico City in an area where the subsoil is slightly more solid than in the city center but nonetheless required special foundation efforts. Mexico City was built on a former lake. The subsoil consists of clay with very high water content, which magnifies the shockwaves of an earthquake. This is why even mid-level earthquakes cause significant damage to structure in the city.

**Scope of the project:** 243 MAURER Lead Rubber Bearing (MLRB) isolators, consisting of a steel-reinforced elastomeric bearing and an inner lead core. The bearings are designed for seismic movements of up to  $\pm 400$  mm. The largest bearings feature a height of 420 mm, diameter of 850 mm and were designed for a structure load of 5,100 kN.

>> Izmit Bay Bridge / Turkey  
World No. 4 suspension bridge

**Task:** The suspension bridge is located in one of the world's most active seismic zones: Therefore the bridge is designed to resist up to magnitude 8 earthquakes.

**Scope of the project:** MAURER designed, produced and tested all four expansion joints: Two expansion joints (Type DS 28-F, 100 mm gap), each one 25.40 m wide, two expansion joints (Type DS 04-F, 80 mm gap) with 30.40 m wide. For the service limit state the expansion joint accommodates movements of 2,800 mm. During of a 500 year seismic event they can accommodate 7,540 mm. The additional seismic displacement is facilitated by a Fuse Box System, which can be considered as a safety valve.



>> Danube City Tower – tallest building in Vienna/Austria

**Task:** The 220 m tall building vibrates due to wind and earthquake event. The accelerations for a wide range of loads and frequency fluctuations are to be reduced to provide adequate comfort. To do this, a 300-tonne pendulum mass is used in a mass pendulum damper.

**Scope of the project:** MAURER Adaptive Hydraulic Dampers (MHD-A) for 30-80 kN and  $\pm 700$  mm of movement to dampen the 300-tonne-mass pendulum; MAURER Monitoring System for movement, force and acceleration included.

MAURER SE

Frankfurter Ring 193  
80807 Munich

PO Box 440145  
80750 Munich

Phone +49.89.323 94-0  
Fax +49.89.323 94-338

info@maurer.eu  
www.maurer.eu

---

German Engineering since 1876

